



SUBMITTAL

**CBT-SERIES**

CHILLED WATER BUFFER TANK

Models: CBT-120 thru CBT-1040

Submittal Sheet No. CBT-2016A

Date: 6/20

Job Name _____	Submitted By _____	Date _____
Location _____	Approved By _____	Date _____
_____	Order No. _____	Date _____
Engineer _____	Notes _____	
Contractor _____	_____	
Sales Rep. _____	_____	

**Description**

AA tanks ASME Chilled Water Buffer Tanks (CBT) are designed for chilled water systems with insufficient water volume capacity in relation to the chiller capacity. Relatively low water volume systems require additional "buffer" capacity for the systems to eliminate problems such as excessive chiller cycling, poor temperature control, and erratic system operation. The properly sized CBT adds the necessary volume to "buffer" the system volume.

**Construction**

Shell: Carbon Steel  
 (Available in 304 / 316 Stainless Steel)  
 Exterior: Primer Painted

**Performance Limitations**

Maximum Design Temperature: 450°F  
 Maximum Design Pressure: 125 PSIG\*  
 \*200 & 250 PSIG available



Model Number	Part Number	Tank Volume (Gallons)	Tagging Information	Quantity
CBT-120	55240120	120		
CBT-200	55300200	200		
CBT-300	55360300	300		
CBT-500	55420500	500		
CBT-850	55540850	850		
CBT-1040	55601040	1040		

**Typical Specification**

Furnish and install, as shown on plans, a CBT- \_\_\_\_\_ as manufactured by AA tanks Company. The tank shall incorporate a baffle to promote tank water storage temperature stratification. The system water connections must be \_\_\_\_\_" (NPT/flanged/grooved). The CBT must be constructed in accordance with the most recent addendum of Section VIII Division 1 of the ASME Boiler and Pressure Vessel Code and constructed and stamped for 125 PSI working pressure @ 450°F.

Each tank shall be AA tanks model number CBT- \_\_\_\_\_ or approved equal.

25110 THOMAS DR • WARREN, MI 48091 • (586) 427-7700 • (586) 427-7895 FAX • www.aatanks.com



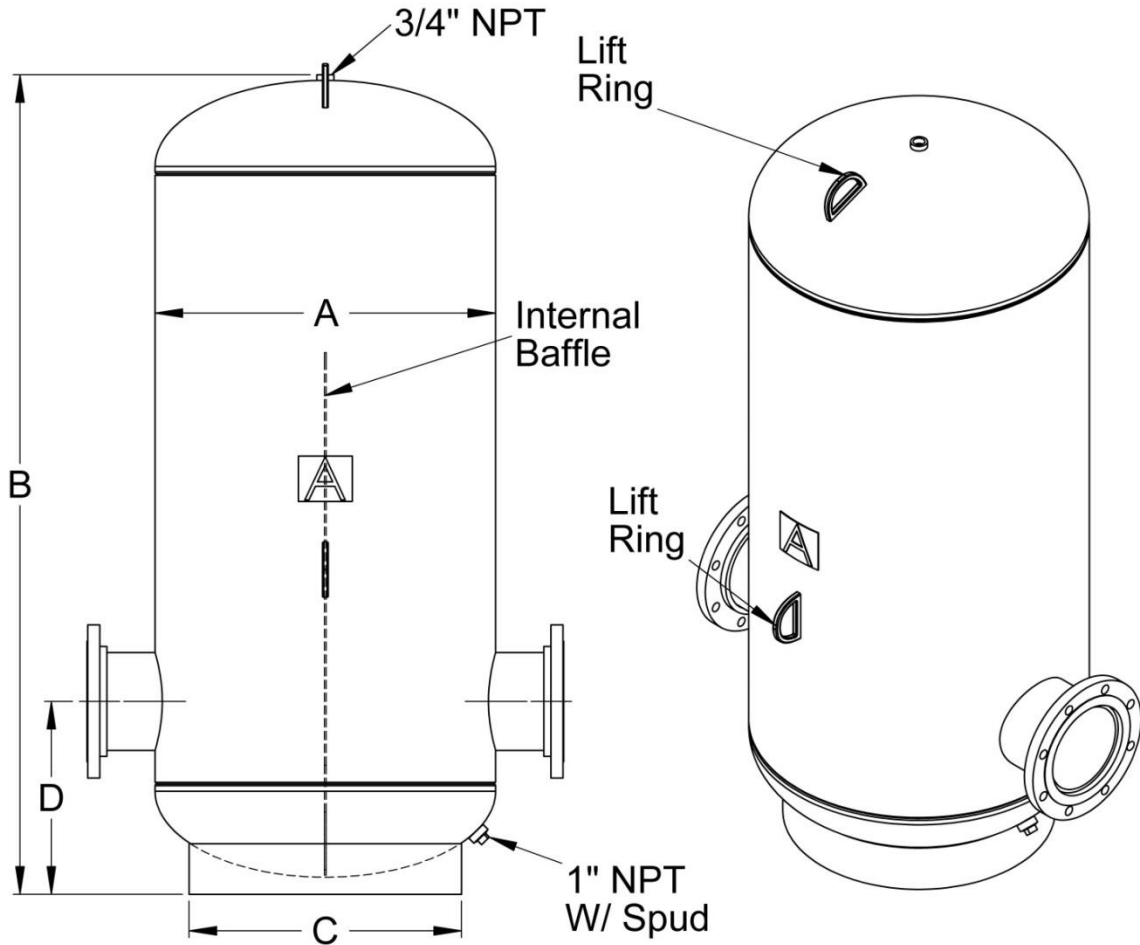

CBT-120 thru CBT-1040

**Dimensions & Weights**

Model Number	Dims. In Inches			(D In Inches) for Various Connections								Max. Shipping Wt (lbs)
	A	B	C	2" Flg	2 1/2" Flg	3" Flg	4" Flg	5" Flg	6" Flg	8" Flg	10" Flg	
CBT-120	24	60	20	12	12 1/4	12 1/2	13	14	14	15	16	410
CBT-200	30	72	24	14	14 1/4	14 1/2	15	16	16	17	18	555
CBT-300	36		30	15 3/4	15 3/4	16	16 1/2	17	17 1/2	18 1/2	19 1/2	690
CBT-500	42	90	36	17 1/2	17 3/4	18	18 1/2	19	19 1/2	20 1/2	21 1/2	1150
CBT-850	54	96	48	21	21 1/4	21 1/2	22	23	23	24	25	1945
CBT-1040	60		54	22 3/4	23	23 1/4	23 3/4	24 1/4	24 3/4	25 3/4	26 3/4	2138

**Notes:**

- Insulation optional
- Larger size, grooved, or NPT connections available