



SUBMITTAL

WVA-SERIES

AIR & DIRT SEPARATOR

Models: WVA-2 thru WVA-12

Submittal Sheet No. WVA-2016A

Date: 8/20

Job Name _____	Submitted By _____	Date _____
Location _____	Approved By _____	Date _____
_____	Order No. _____	Date _____
Engineer _____	Notes _____	
Contractor _____	_____	
Sales Rep. _____	_____	

Description

AAtanks WVA series Air & Dirt Separators are designed to eliminate entrained air and separate debris associated with start-up and maintenance of any hydronic systems. The design incorporates a skim valve, used to eliminate floating debris, removable end cover for coalescing medium access, and an air vent to automatically release air from the separator.

Construction

Shell: Carbon Steel
 Coalescing Medium: Stainless Steel
 Blow Down Valve (optional): Bronze
 Skim Valve (optional): Bronze
 Vent (optional): Cast Iron
 Exterior: Primer Painted

Performance Limitations

Maximum Design Temperature: 250°F
 Maximum Design Pressure: 150 PSIG*

*125, 200 & 250 PSIG available



Model Number	Part Number	Max Flow (GPM)	Tagging Information	Quantity
WVA-2	72302001	69		
WVA-2-NPT	72302012	69		
WVA-2.5	72302035	108		
WVA-2.5-NPT	72302046	108		
WVA-3	72302069	144		
WVA-3-NPT	72302080	144		
WVA-4	72302103	255		
WVA-5	72302137	398		
WVA-6	72302160	570		
WVA-8	72302183	945		
WVA-10	72302206	1440		
WVA-12	72302229	2100		

Typical Specification

Furnish and install, as shown on plans, a WVA-_____ Air & Dirt Separator as manufactured by AAtanks Company. Each separator must be designed with a blow down valve, skim valve, and automatic air vent. The separator must also utilize in its design a stainless steel coalescing medium to aid in the separation of air and dirt in the systems entrained water. The separator must be constructed in accordance with most recent addendum of Section VIII Division 1 of the ASME Boiler and Pressure Vessel Code and shall be constructed and stamped for 150 PSI working pressure @ 250°F.

Each air separator shall be AAtanks model number WVA-_____ or approved equal.

25110 THOMAS DR • WARREN, MI 48091 • (586) 427-7700 • (586) 427-7895 FAX • www.aatanks.com



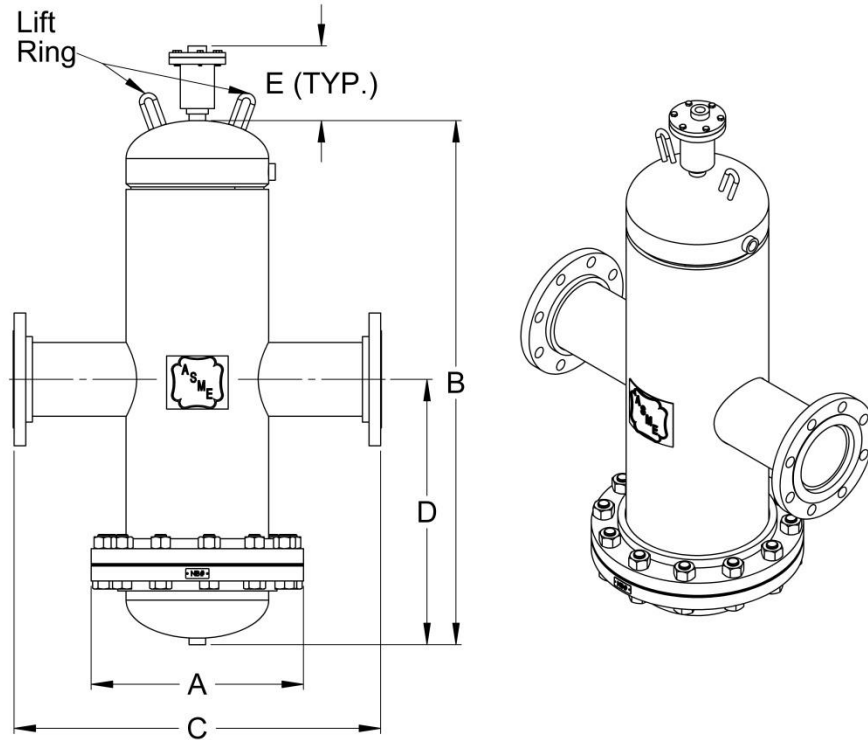

WVA-2 thru WVA-12

Dimensions & Weights

Model Number	Dimensions in Inches						Approx Shipping Wt (lbs)
	Connection Size	A	B	C	D	E	
WVA-2	2	9	23	15 1/4	11 1/2	8 5/8	100
WVA-2-NPT				9			90
WVA-2.5	2.5	10		15 3/4			125
WVA-2.5-NPT			10 1/2	115			
WVA-3	3	11	20 1/4	14 1/2	150		
WVA-3-NPT			12 3/4		130		
WVA-4	4	13 1/2	20 5/8	19 1/2	250		
WVA-5	5	16	27 3/4		310		
WVA-6	6	19	49	24 1/2	375		
WVA-8	8	23 1/2			700		
WVA-10	10	27 1/2	65	32 1/2	1000		
WVA-12	12	32	76	42 1/2	38	1500	

Notes

- Trim package is optional.